







ASSEMBLY INSTRUCTION

opticalCON DRAGONFLY®

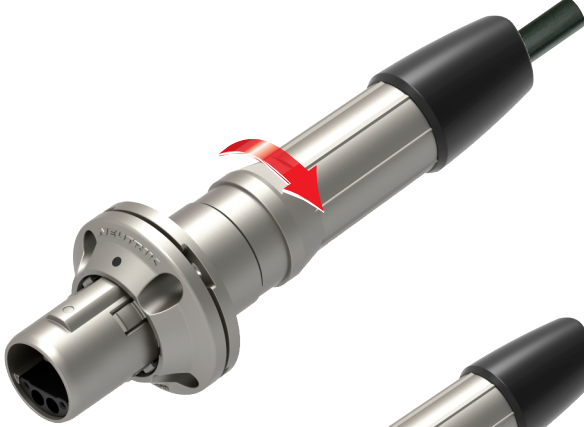
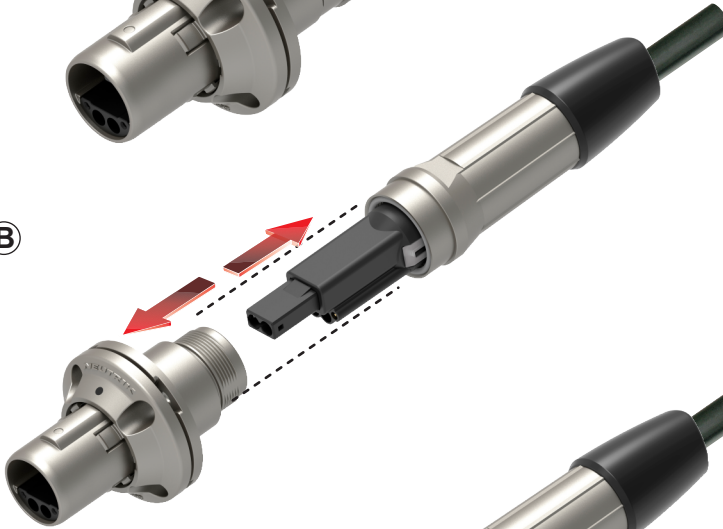
Cable Assembly | NKO2SMW-XP-*

1 Assembly of the pulling tool FORP-XP

- (A)**  Unscrew the male connector's anti-kink boot.
- (B)**  Remove the male connector's front housing.
▶ We will need this male connector later for mount into the panel.
- (C)**  Place the pulling tool (FORP-XP to be ordered separately) on the male connector.
- (D)**  Screw the pulling tool on the male connector.
- (E)**  Pull the cable using the pulling tool to the panel on which male connector should be mounted. A snap hook can be attached.

Pulling tool:

- FORP-XP





2 Chassis male assembly and panel mounting

Plug side / Device

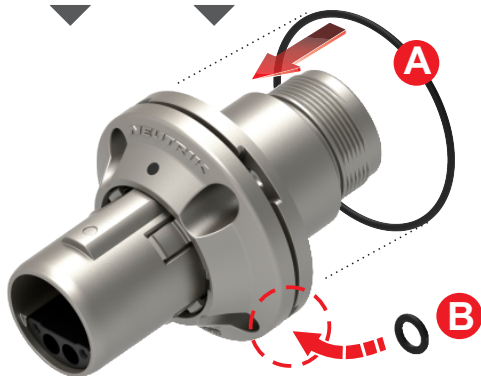

Unscrew the pulling tool.

Insert the front housing into the panel cutout as described below and screw the connector to the front housing.

- (A) Position the large O-ring from the backside onto the chassis.
- (B) Place a small O-ring in the screw hole

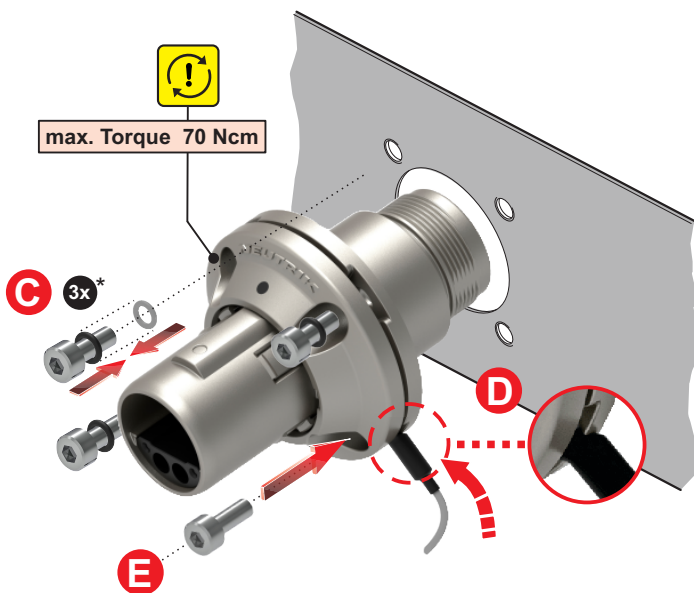

- (C) Position the small O-rings onto the remaining 3 screws*.
- (D) Mount the chassis on the panel. Push the mounting eye into the slot.

Important: the O-ring is underneath.

- (E) First position the screw without O-ring in the hole together with the mounting eye. Secondly mount the other 3 screws and tighten all screws with 70 Ncm.

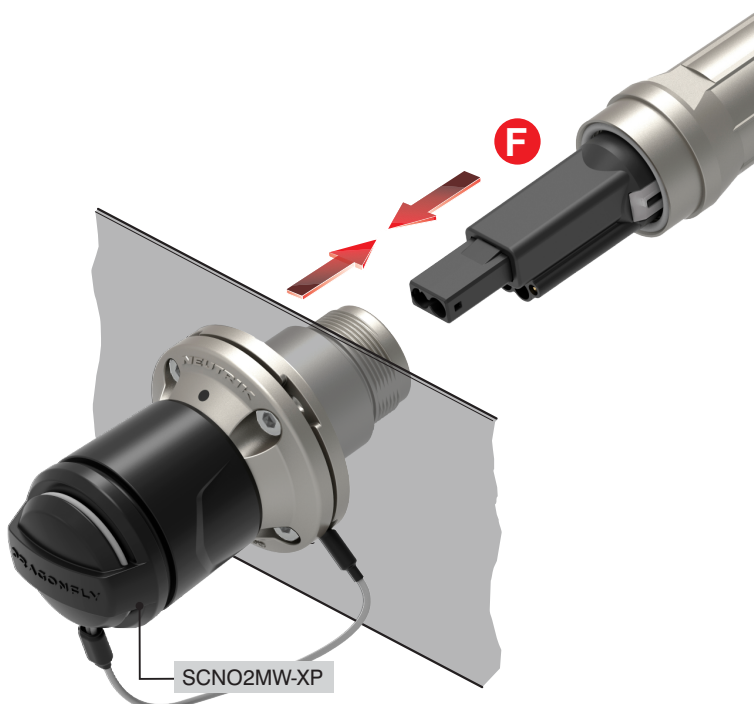

- (F) Position the connector housing into the front housing and tighten lightly.

* USE FOLLOWING SCREWS:

- M3 DIN 912 or
- UNC 4-40 PAN HEAD



G

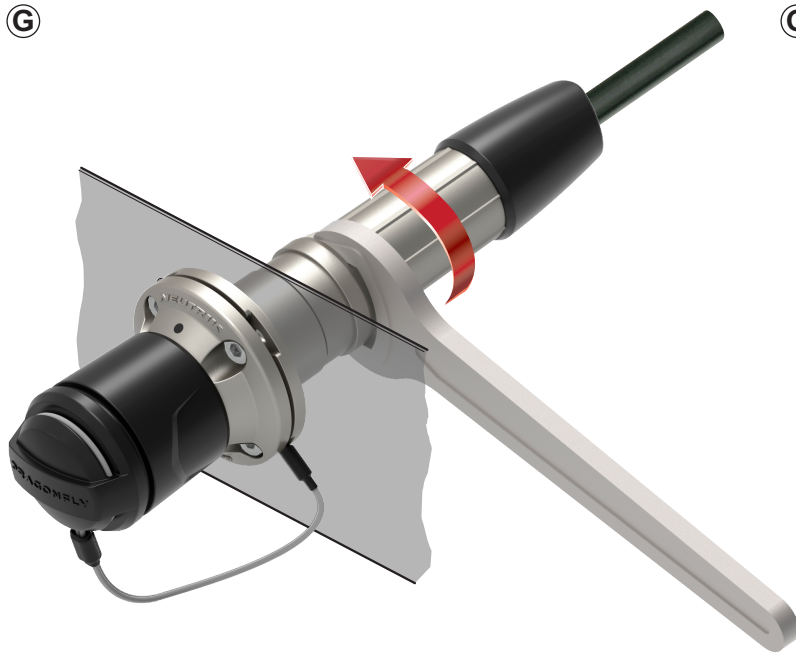

G Tighten the connector with the open-end wrench.

Wrench size: 19 mm
Torque: 10 Nm

Close the chassis with the sealing cover. When the connectors are mated, the sealing cover can be put together with the cable connector cover to keep the interior clean.

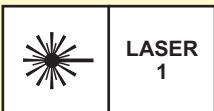

CAUTION:
Laser radiation, do not look directly into beam of light!



Find more details on
www.neutrik.com

Neutrik AG LI T: +423 / 237 24 24 F: +423/232 53 93
Neutrik USA Inc. USA T: +1 704 / 972 3050 F: +1 704/438 9202
Neutrik (UK) Ltd. UK T: +44 1983 / 811 441 F: +44 1983/811 439
Neutrik Vertriebs GmbH DE/NL/AT/DK T: +49 8131 / 280 890 F: +49 8131/280 830

Neutrik France FR T: +33 1/4131 6750 F: +33 1/4131 0511
Neutrik Tokyo Ltd. JP T: +81 3/3663 4733 F: +81 3/3663 4796
Neutrik Hong Kong Ltd. HK T: +852/2687 6055 F: +852/2687 6052

Draft. Nr.: BDA 632 V2 | Update: 2021-12-16 | Data subject to change without prior notice. © 2021 NEUTRIK®, NEUTRIK® are registered trademark of Neutrik AG. ALL RIGHTS RESERVED.

www.neutrik.com

NEUTRIK®